

Energy Conservation of Commercial Facilities

(Department Stores, General Merchandise Stores, and Shopping Centers)

Major points, measures, and successful cases of energy conservation of commercial facilities



The Energy Conservation Center, Japan



Introduction

The first commitment period of Kyoto Protocol started in FY2008, which requires us to achieve a target of reducing greenhouse gas emissions to 6% below the base year (FY1990) levels by FY2012. Approximately 87% of the greenhouse gas is comprised of carbon dioxide (CO₂) from energy consumption. The CO₂ emissions have been significantly growing especially in civilian business sectors and enhancement of drastic measures has become an urgent need.

This brochure is intended for owners of commercial facilities and persons in charge of energy conservation promotion or energy facility management, explaining the points, measures and the case examples of energy conservation based on our investigation data. We hope that you will find the information taking account of characteristics in energy consumption particularly seen in operations of commercial facilities helpful for your activities toward better energy conservation practices.

C O N T E N T S

1	Characteristics of Energy Consumption at Commercial Facilities	2
2	Energy Consumption Structure of Commercial Facilities	3
3	Energy Conservation Measures at Commercial Facilities	5
4	Energy Conservation Measures for Different Departments of Commercial Facilities	7
5	Energy Conservation Measures for Different Installations and Equipment at Commercial Facilities	9
6	Successful Cases of Energy Conservation Measures of Commercial Facilities	11
7	Effective Tools and Techniques for Promoting Energy Conservation by Improved Operation	14

1

Characteristics of Energy Consumption at Commercial Facilities

The following graphs show the characteristics of energy consumption at large commercial buildings in the size of designated energy management factories located in the middle part of the county (between Tokyo metropolitan area and Kansai metropolitan area), including 39 department stores, 12 general merchandise stores, and 15 shopping centers.



The distribution of total floor space of surveyed buildings

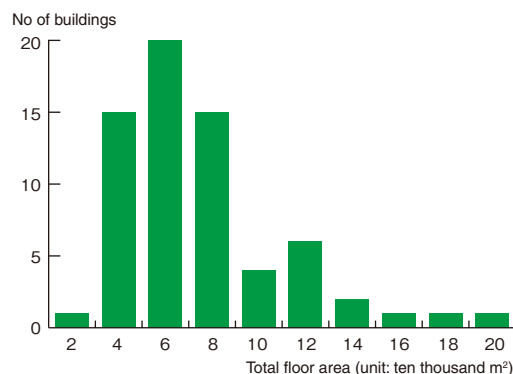

Energy consumption by target facilities percategory of business

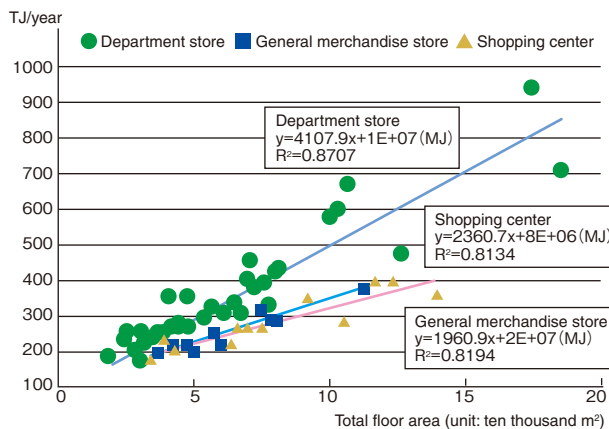

Energy consumption trend of typical facilities from each category

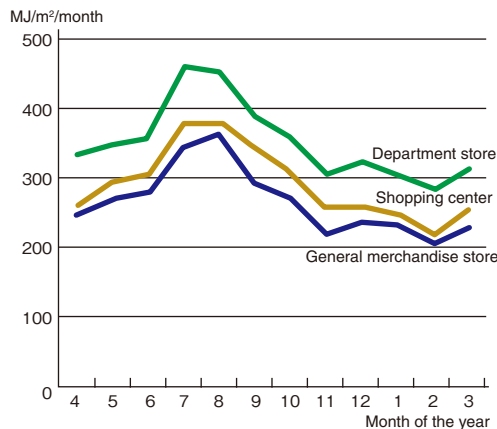

Energy intensity of different categories of business

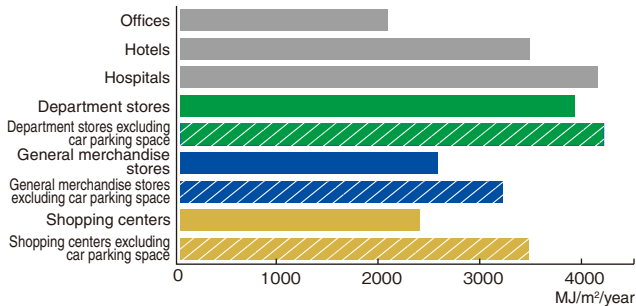

The proportion of heat (fuel) and electricity consumption

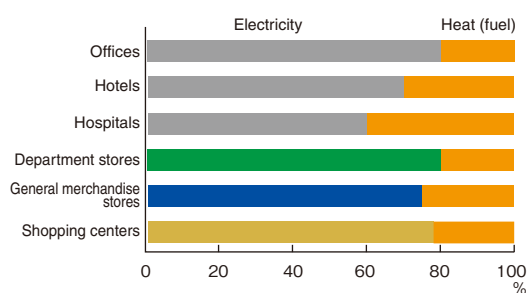

2

Energy Consumption Structure of Commercial Facilities

Energy intensity of commercial facilities vary depending on their types of business and/or operation styles. The following graphs illustrate the differences.

In order to promote energy conservation initiative, it is necessary to know energy intensity of each department (such as food sales, commodity sales, and the sections behind the shop front). As a way of obtaining such information, ECCJ provides a tool for energy specific unit management (computer software to estimate energy intensity and their breakdowns) for free.

Energy intensity of commercial facilities
(Type 1 and Type 2 designated energy management factories) (excluding car parking space)

	Department store	General merchandise store	Shopping center	Average of all categories
Number of facilities	39	12	15	(66)
Average (MJ/m ² /year)	4,123	3,140	3,452	3,572
Maximum (MJ/m ² /year)	6,149	3,760	4,273	4,728
Median (MJ/m ² /year)	3,842	3,017	3,428	3,429
Minimum (MJ/m ² /year)	2,624	2,668	2,821	2,704

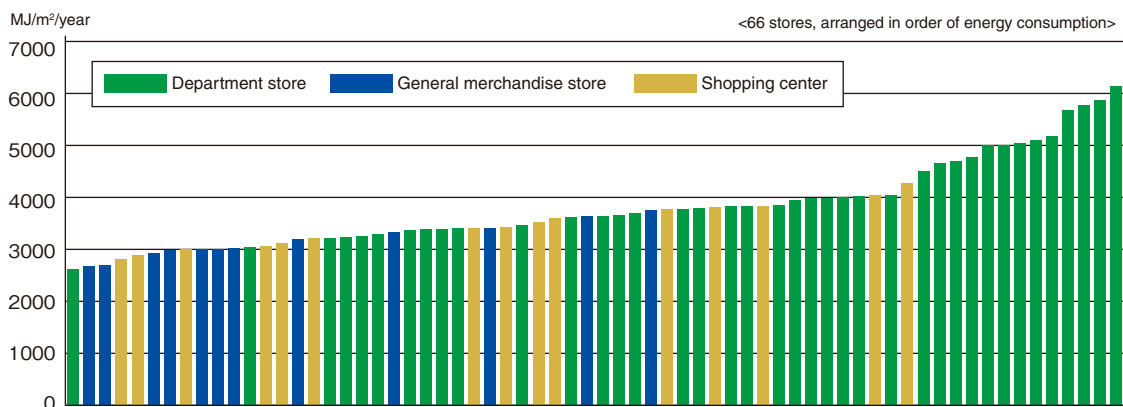

Proportion of car parking space to total floor space of commercial facilities

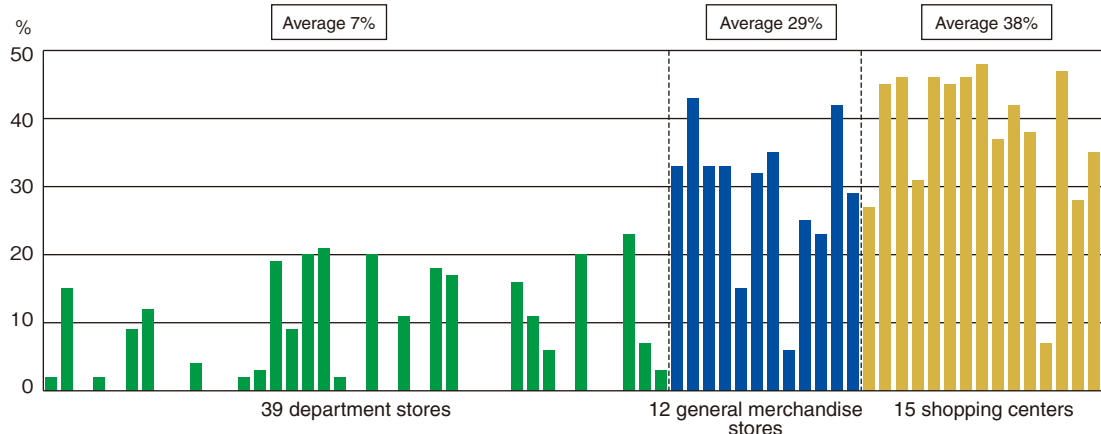

Energy consumption structures of general merchandise stores and department stores are shown below. The largest share of the general merchandise stores is represented by energy for air-conditioning, which accounts for approximately 40%, followed by lighting and electrical outlets, and chillers, water and refrigerators. The department stores have almost the same shares in lighting and electric outlets and air-conditioning, accounting together for almost 80% of total energy consumption.

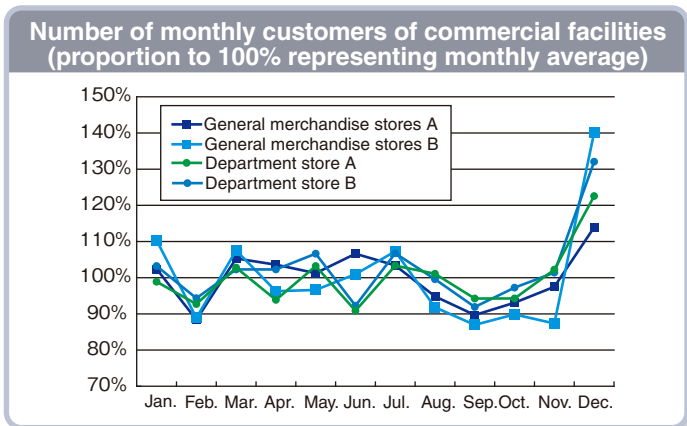
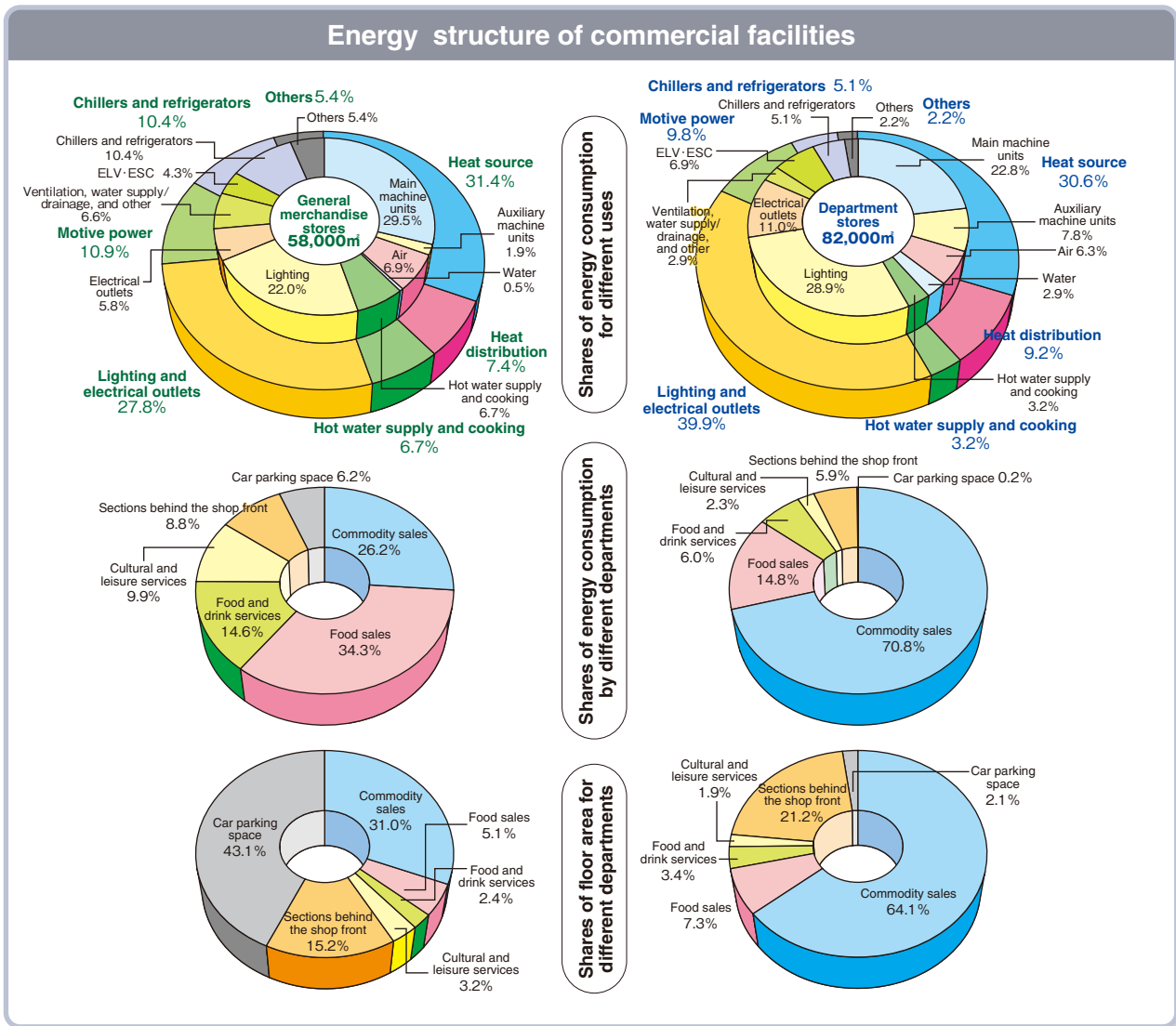

Average business hours of commercial facilities

Category of business	Average annual business hours
Department stores	3,633 (362 days)
General merchandise stores	4,030 (364 days)
Shopping centers	4,320 (363 days)

3

Energy Conservation Measures at Commercial Facilities

The following are energy conservation measures which are often implemented in commercial facilities.

Their adoption rates vary depending on type of business.

Air conditioning

- Stop outside air intake during warm-up operation
- Control outside air intake by CO₂ concentration level (800 to 990 ppm)
- Outside air cooling
- Heat recovery using total heat exchanger
- Intermittent operation of air-conditioning units
- Turning off air-conditioning units before closing time

Control outside air intake by CO₂ concentration level



Improvement of various functions of building energy management system (BEMS)

- Calculation and summarization of energy consumption data
- Scheduled operations
- Monitoring of operations conditions
- Management of indoor air quality
- Control of consumed energy
- Measurements of electricity for each feeder or transformer
- Installation of flowmeters, calorimeters, and thermometers

Reduction of power required to operate fans

- Adoption of high-efficiency fans
- VAV (variable air volume) control
- Control of revolution speed through installation of inverter device to light duty fans
- Replacement motors with higher efficiency ones (estimated energy conservation ratio: 5%)
- Installation of energy-saving belts (estimated energy conservation ratio; 3 to 4%)

Heat source

Chiller

- Energy conservation and reduction of environmental burden through modifying centrifugal (turbo) chillers using specified chlorofluorocarbon (CFCs) to chiller units using CFC alternatives
- Divide required equipment capacity into appropriate units
- Change chilled-water temperature setting at summer and at intermediate seasons

Boiler

- Optimization of air ratio
- Dividing required equipment capacity into several units

EHP/GHP

- Taking preventive measures against short circuit of outdoor condensing units
- Reduce the length of coolant pipes

Utilization of natural energy

- Solar power generation
- Solar heat water heater

Cooling tower

- On/off control of cooling tower fans
- Cleaning and replacement of fillers
- Control of cooling water concentration level
- Consideration of free cooling system

Reduction of thermal load from windows, sashes, and glasses

- Reduction of window space Enhance insulation and airtight sashes
- Use of heat reflecting or double-glazed glasses

Reduction of water consumption

- Automatic water faucet
- Installation of water-saving flush valves (estimated water saving ratio: 20%)
- Installation of motion sensor to urinals
- Installation of imitation sound generating device in ladies toilet
- Use of treated wastewater as flush water
- Installation of well water treatment system to produce drinking water



Well water treatment system to produce drinking water

Elevators

- Reduction of the number of units in service by implementing more optimized layout
- Enhance Inverter control (estimated energy conservation ratio: 30%)
- Recycling of energy consumption using regenerative control device for electric power (estimated energy conservation ratio: 15%)
- Control (turning on and off) ventilation fans in elevator motor room using a thermostatic system

Indoor car parking space

- Change of ventilation fan control method from a schedule-based to CO-concentration level-based method
- Dividing controllable lighting area into smaller partitions



Carbon monoxide (CO) meter for controlling ventilation based on CO concentration level at car parking space

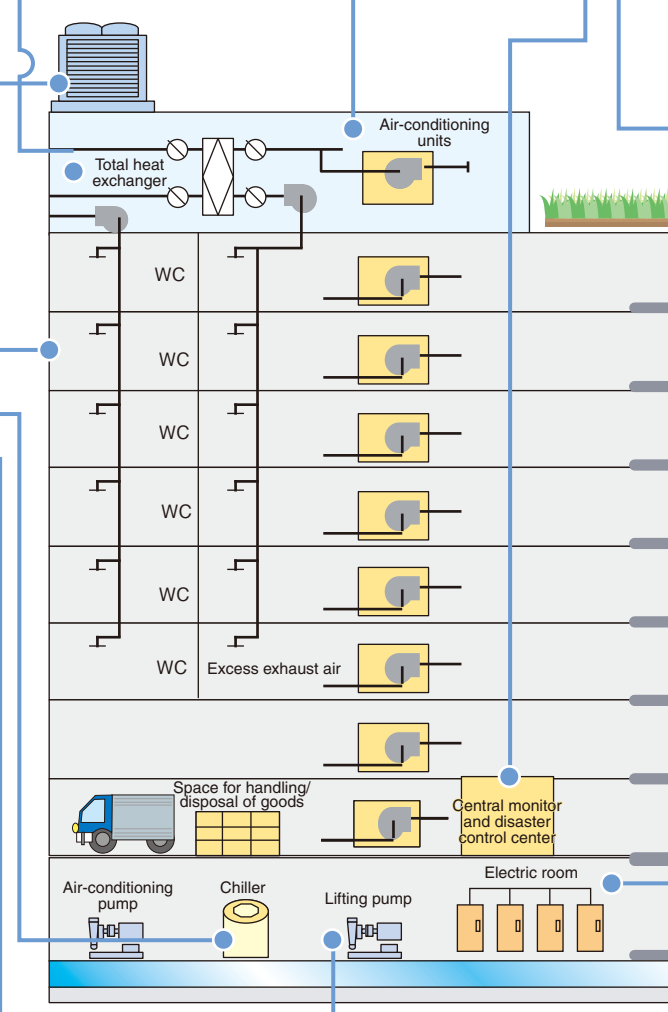



Adoption rate of energy conservation techniques at commercial facilities

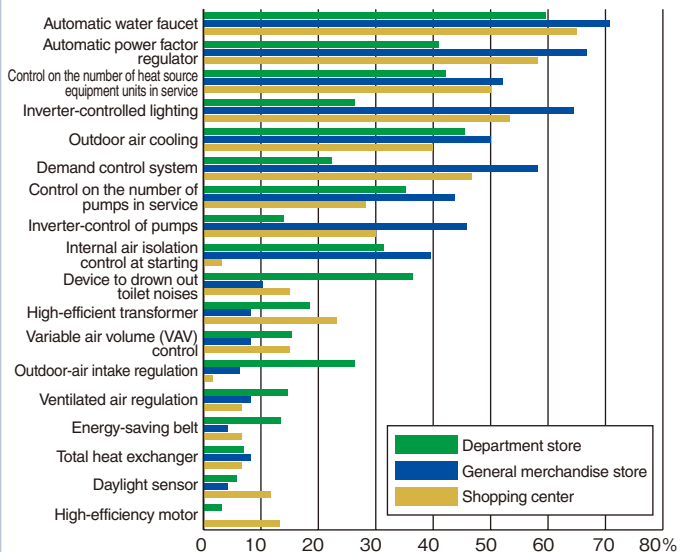

Adoption rate of equipment and facilities designed for environmental improvement at commercial facilities

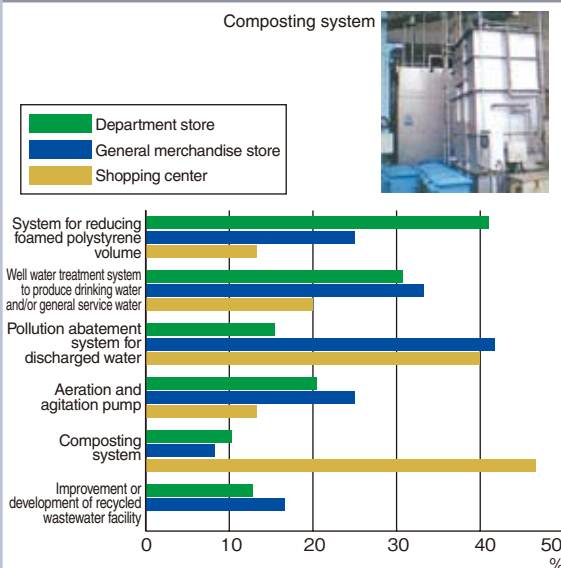

Prevention of unnecessary outdoor air from entering into building

- Prevention of outdoor air entry at entrances and exits
- Checking that a damper is closed when air-conditioning is turned off
- Installation of airbrake room at door way
- Maintaining room air pressure positive

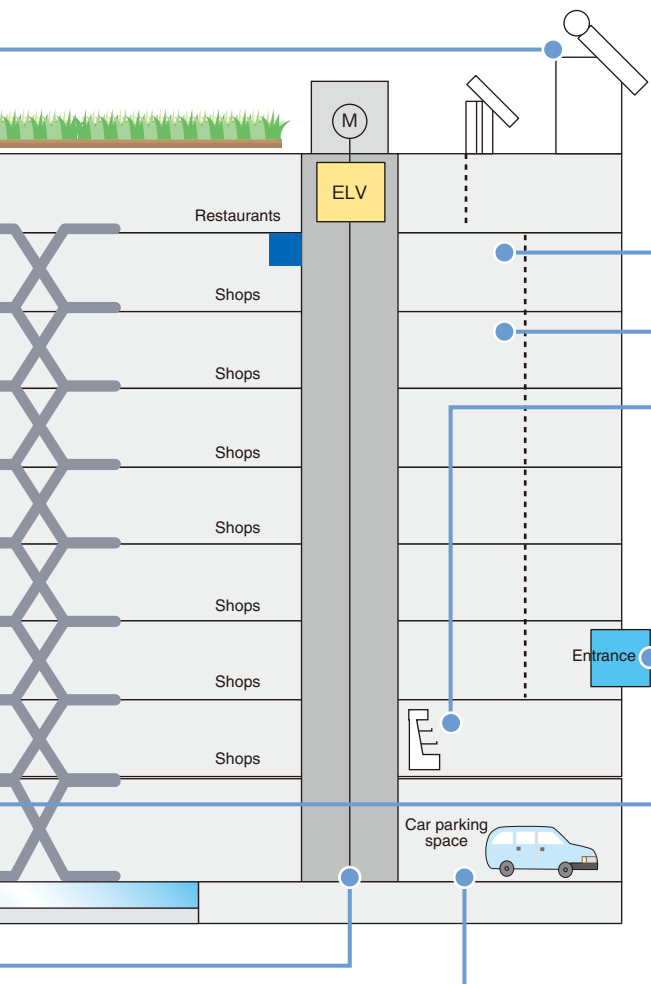

Floor planning

- Utilizing service space as a buffer area to insulate heat from exterior walls
- Place the openings in the lee of the building
- Phased arrangement of air-conditioning space

Indoor lighting

- Use of less indirect lighting fixtures
- Dividing lighting area controlled by switch circuit into smaller partitions
- Changing room color to lighter tone
- Use of less incandescent lamps
- Scheduled lights on and off system
- Use of high-frequency (HF) lighting fixtures
- Control of lighting system taking advantage of daylight
- Maintenance of proper illuminance

Food Showcases

- Use of energy-conserving food showcases
- Installation of night covers (insulation covers)
- Eliminating use of showcases which discharge heat indoors



Reduction of electric distribution loss and power loss

- Modification of the system to shorter distribution route
- Use of wires with thicker size

Electric power receiving and transforming

- Improvement transformer to the high-efficiency one (total loss is reduced to one third of old type transformer)
- Review the balance of transformers load and re-configure of them.
- Separating feeders for daytime and nighttime systems so that the transformer in the latter system can be turned off.
- Turning on and off exhaust fans using a thermostat system
- Reduction of peak demand (maximum power under electric power-supply contract) through implementation of a heat storage system
- Demand control

Installation of cogeneration system

- Improvement of efficiency in heat and electricity consumptions according to load levels
- Reduction of peak demand (maximum power under electric power-supply contract)
- Installation of absorption chillers with waste heat recovery system
- Implementation of hot-water supply with waste heat recovery system

4

Energy Conservation Measures for Different Departments of Commercial Facilities

The following are energy conservation measures for different departments, which are helpful for you to promote your energy conservation initiative.

Commodity Sales department

This department has the largest share of floor area in a facility. In a department store, the commodity sales section on the first floor has particularly high lighting illuminance and a wide use of incandescent lamps, leading to significantly large electric power consumption for lighting. Another issue is that outdoor-air blowing into the building from entrances on the first floor puts a significant burden of its air-conditioning load.

Important points for the measures

- 1 Adopt air-break room at door way.
- 2 Improved arrangement of lighting equipments with effective impact should be made so that the number of incandescent lamps can be reduced. Utilization of daylight for lighting purpose around entrances and near windows should also be considered.
- 3 Energy-saving lighting equipments with inverter device should be installed.
- 4 Excess air cooling or heating should be avoided.
- 5 Outside air cooling should be implemented during winter and intermediate seasons.
- 6 Proper amount of outside air intake should be taken in to the building in proportion to the number of occupant, with CO₂ concentration level control during air-conditioning.

Administrative department

A majority of energy consumption in office is air-conditioning, lighting, and outlets. Unlike sales floor, where entirely turning lights on and off as scheduled is an effective measure, lighting equipments in administrative department are usually controlled separately using a switch on the wall. A company cafeteria has an energy consumption structure similar to food and drink service department.

Important points for the measures

- 1 Since offices and the back yards have different operating hours for different purposes, an individual air-conditioning should be adopted.
- 2 Lighting area should be divided into smaller partitions to turn off lights wherever unnecessary.
- 3 Temperature setting for air-conditioning should be at 20°C during winter and 28°C during summer.
- 4 Lighting equipments should be replaced to inverter type.
- 5 Daylight should be utilized for lighting in the office. A motion sensor device should be installed to turn on/off lights for such as locker rooms, etc.

Car parking space

Department stores often have a basement parking area, a mechanical parking lot and a three-dimensional parking lot, and a majority of large shopping centers has outdoor parking lot or outdoor parking with semi-open walls. A shopping centers with station buildings typically do not have their own car parking space and often share a public parking space with other facilities.

The major energy consumption of car parking space is for ventilation and lighting, and it has fairly smaller energy density than other departments.

Important points for the measures

- 1 In addition to securing minimum necessary lighting level, the lighting area should be divided into smaller partitions to allow strict control based the number of cars parked in the area.
- 2 A CO sensor device should be installed to control ventilation system based on the standard CO level.
- 3 Alert drivers to encourage to stop idling practice.
- 4 Some improvements which could make driving speed slower should be added in the drive ways in order to reduce exhaust gas emissions.

Food sales department

Food sales department is characterized by its high energy consumption density, especially freezing / refrigeration for food, in contrast with its small area ratio in the facility. The customer density per certain area is larger than others, especially in the evening. In recent years, more cooking in sales area is needed due to increased demands for cooked foods, catering service, etc., resulting in upward trend of energy consumption for cooking.



▲ Food chiller

Important points for the measures

- 1 Indoor temperature of supermarket tends to be too lowered influenced by the chill of the freezing / refrigeration cases for foods. Such excess cooling should be avoided
- 2 Foods should be kept at proper temperature, avoiding excess cooling of open-type showcases.
- 3 L-leakage of the chill after closing the store should be prevented using night covers or other measures. Glass doors of freezing cases should be closed as frequently as possible.
- 4 Decrease the freezer units with an integrated compressor.

Energy consumptions required by hot-water supply and cooking in food department (MJ/year)
= a x food sales floor area m² (a= 4,500 (maximum), 3,000 (median), 1,000 (minimum))

Energy conservation measures for freezers and refrigerators

- 1 Lights for showcases should be turned off after shop hours.
- 2 The condenser tubes should be cleaned periodically.
- 3 Preventive measures against short circuit of outdoor condensing units should be taken in order to mitigate degradation of their condensation capacity.
- 4 Adopt showcases with air curtains and an energy-saving type.
- 5 Arrangement of lamps inside in showcases should be changed to single row (single-row and double-row lamps should not have a much difference in visual effect).
- 6 Installation of multi-chillers and hot gas defrosting system should be considered.
- 7 Freezers and refrigerators should be placed next to each other whenever possible so that less area of their walls is exposed.
- 8 Separate refrigerators according to cooling temperature range.
- 9 For open-type showcases which do not require very low temperature, such as for fruits and vegetable or dairy products, adoption of off-cycle defrosting system should be considered.

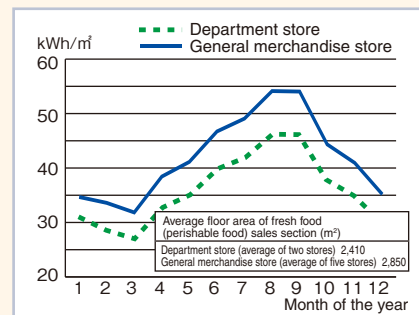

Freezing/refrigerating load of food sales department in department stores (kWh/m²) = 435 kWh/m²/year

Freezing/refrigerating load of food sales department in general merchandise store (kWh/m²) = 504 kWh/m²/year

Food and drink service

This department is characterized by higher energy consumption density than others; with a large amount of gas and electricity consumptions for cooking, and accordingly HVAC in contrast with its small area ratio. Due to wide use of indirect lighting and pendant lamps the lighting load is larger in proportion to their illuminance level.

Important points for the measures

- 1 Pilot flame of gas cookers should be shut off as soon as it becomes unnecessary. Air orifices should be regulated to allow perfect combustion with proper heat.
- 2 Increase/decrease the air volumes of exhaust fans and outside-air processing unit according to consumption of gas to minimize electricity consumption.
- 3 Remove food leftovers before washing to reduce water/hot water supply consumption.
- 4 The refrigerators/freezers for food storage be managed to minimize access frequency and time.
- 5 Water, gas, and electric energy consumption should be measured per branch store to check the amount of their usage.
- 6 A central monitoring system should be developed so that it detects an individual air-conditioning unit forgotten to be turned off, if any.
- 7 Maintenance for facilities and equipment, including air-conditioning units and chillers, at different branch stores should not be managed separately by each store, but entirely by the store operator, following establishment and implementation of a maintenance standard.

5

Energy Conservation Measures for Different Installations and Equipment at Commercial Facilities

The following are energy conservation measures for the equipments (machines, lights, etc.) installed at commercial facilities.

1. Energy conservation measures for heat source equipment

- 1 Required capacity of equipment, such as boilers, chillers, chilled/hot water generators, should be divided into several units.
- 2 Thermal insulation of bodies of boilers, steam headers, and valves should be enhanced.
- 3 Replacement of centrifugal (turbo) chillers using specified CFCs with the ones using CFC alternatives should be considered, striving for improved coefficient of performance (COP) and reduced environmental impact.
- 4 Inspections and preventive measures should be taken to see outdoor condensing units for short-circuited.

2. Energy conservation measures for heat-conveying (fans, pumps, piping) equipment

- 1 Quantity control of equipment should be adopted.
- 2 VAV (variable air volume) system should be adopted.
- 3 VVV (variable water volume) system should be adopted.
- 4 Chilled-water conveyance system with large temperature difference should be implemented.
- 5 Inspection and improvement should be made on insulating performance of ducts, piping, and other parts.
- 6 An inverter device should be installed to chilled water pumps. And grasp the a total chilled water flow and set a proper frequency according to the required flow
- 7 Three-way valves of chilled water system in air handling unit (AHU) should be replaced with two-way valves so that amount of circulated chilled water is reduced and, thus, power for water conveyance is reduced accordingly.
- 8 In an establishment with a heat storage tank such as for chilled water storage, a semi-closed chilled water system with a plate-type heat exchangers and other devices should be adopted to reduce energy consumption of chilled water pumps.

3. Energy conservation measures for HVAC equipment

- 1 Total heat exchanger with outdoor air intake should be installed.
- 2 Optimized outdoor-air intake in accordance with indoor CO₂ concentration level should be achieved through some measures such as adoption of outsider cooling during winter and intermediate seasons.
- 3 A patterned outside air-intake control based on the number of customers in the building should be adopted to allow only minimum necessary amount of air is taken into the building.
- 4 Ventilation for parking space should be controlled by a CO sensor device.
- 5 Inverter device should be installed for further energy conserving operations.
- 6 An evaporation unit should be installed where their piping for coolant can be as short as possible and be arranged as straight as possible.
- 7 If there are any walls or obstacles near the outdoor condensing units, a proper space between them should be kept. Also the units should be installed where they would not be exposed to radiation heat from sunlight or other types of heat sources.
- 8 Anemostats and blind-shaped openings for air-conditioning or ventilation should be properly maintained so that outlets and inlets of rooms would not be blocked.
- 9 Wind direction control device of air outlet, if any, should be adjusted so that the cooled air is blown in horizontal direction and the warm air is blown to downward direction. Effective and efficient operations with such measure could eliminate temperature differences between the room air in upper and lower layers.
- 10 Direct entry of outdoor heated (or cold) air into the store should be prevented by way of installing air-break room or air curtains at the doorway of the store.
- 11 Improved heat insulation measures should be added to walls, roof, and glass windows of the building.
- 12 Cleaning of ducts, inspection for leakage, and appropriate repair should be made regularly.
- 13 Filters and coils of air-conditioning units should be cleaned frequently.
- 14 Maintenance for clogged filter alarm (manometer) should be made properly.
- 15 Heat exchangers should be cleaned regularly.
- 16 When operation of air-conditioning units is stopped for a long period, such as during off-season, the main power switch should be turned "OFF".

4. Energy conservation measures for lighting equipment

- 1 Measures such as adopting lighting control system, dividing lighting switches into smaller partitions, and turn off the area unnecessary and to reduce lighting hours before/after store hours.
- 2 Installation of occupancy sensors in to the hallways of backyard and locker rooms should be considered.
- 3 Daylight should be utilized for lighting.
- 4 Lighting reflectors or shades should be installed to lighting fixtures.
- 5 Lighting fixtures should be cleaned periodically.
- 6 Colors of ceilings, walls, and floors should be changed to lighter tone with higher reflection rate.
- 7 Lighting fixtures with high efficiency (e.g. inverter-controlled lights) device should be installed.
- 8 More efficient lighting fixtures with higher light reflection and transmission should be installed.
- 9 Fluorescent lamps should be replaced periodically.

5. Energy conservation measures for water supply/ drainage and sanitation facilities and equipment

- 1 Water-saving equipment should be installed.
- 2 Water reservoirs level should be controlled to prevent frequent on/off of pumps for discharge sewage water, general service water, spring water, or rainwater.
- 3 Installation of facilities and equipment which use recycled wastewater or well water should be considered.
- 4 Leakage due to degraded packing of water taps should be prevented.
- 5 Capacity of water lifting pump should be checked to see if it is appropriate. If it turns out to be too high, installation of inverter device should be considered. Improvement of the pump to the unit with appropriate capacity should also be considered when replacement is needed, striving for reduction of peak power.
- 6 If a large difference between designed inflow rate and actual rate is found in recycled wastewater facilities, sewage treatment tank (abatement system), etc., it could cause excess operation of blowers and others, leading to higher DO (dissolved oxygen) level and excessive aeration. To solve the problem, measures to reduce aeration power, such as intermittent operations, should be sought.

6. Energy conservation measures for electric power receiving and transforming equipment

- 1 Electric transformers should be replaced with the higher efficiency transformer in order to reduce a total loss. Replacement or improvement should be made starting from older equipment or equipment with lower annual load factor, so that higher improvement effect can be expected.
- 2 Unbalanced load per bank should be addressed.
- 3 In order to maintain proper indoor temperature, a control method for air-conditioning or ventilation of electric room should be changed from a timer-controlled to thermostatic controlled. The temperature setting should be around 35°C.
- 4 Energy conservation measures and data analysis through implementation of building and energy management system (BEMS) and reconstruction of measurement and control functions should be promoted.

Comparison of illuminance between general merchandise stores and department stores

Although department stores and general merchandise stores have similar level of illuminance, there is a significant difference between their electric consumptions. It is assumed that the gap is attributable to the difference in the ratio of used incandescent lamps.

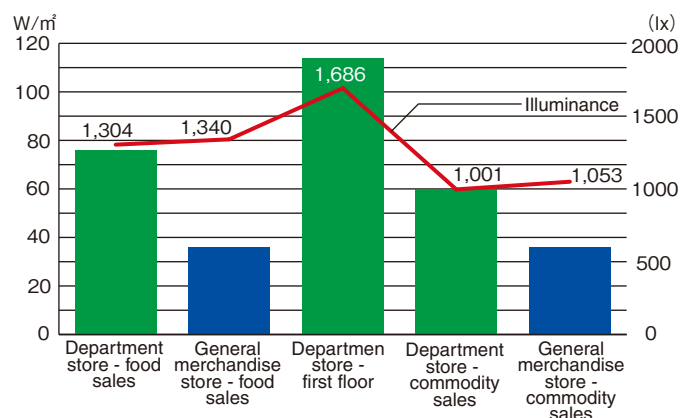

6

Successful Cases of Energy Conservation Measures of Commercial Facilities (1)

Successful energy conservation measure at department store - 1

A modification was made to have different time settings for starting air-conditioning units to precool or warm up the store before its opening at 10:00 am in different seasons. It was found that, during the seasons with moderate climate, the air-conditioning operation could be started 15 minutes later than during summer and winter, and therefore such delayed operation would require less energy consumption. Assuming that 26 units in the store are operated following the new rule, annual energy conservation for 6,672 kWh in electricity and 24,000 MJ of heat quantity (regional cooling) could be achieved.

◆ Calculation of electricity reduction

Electricity for air-conditioning equipment (26 units) $178\text{kW} \times 1/4\text{H} (15 \text{ mins}) \times 5 \text{ months} \times 30 \text{ days} = 6,672\text{kWh}$

Data on air-conditioning operations on September 22, 2007

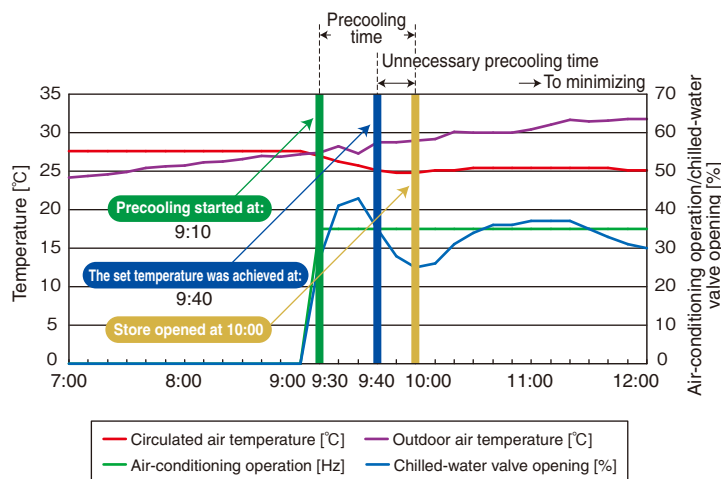

- On September 22, following the start of air-conditioning operation, temperature of circulated air was raised to the set temperature (25°C) at 9:40.
- On October 12, the set temperature was achieved at 9:30, or 10 minutes earlier, although the air-conditioning operation started at the same time as September 22.
- In October, the set temperature can be achieved without any problem even though the start of air-conditioning operation is delayed by 10 minutes or longer compared to September.



Data on air-conditioning operations on October 12, 2007

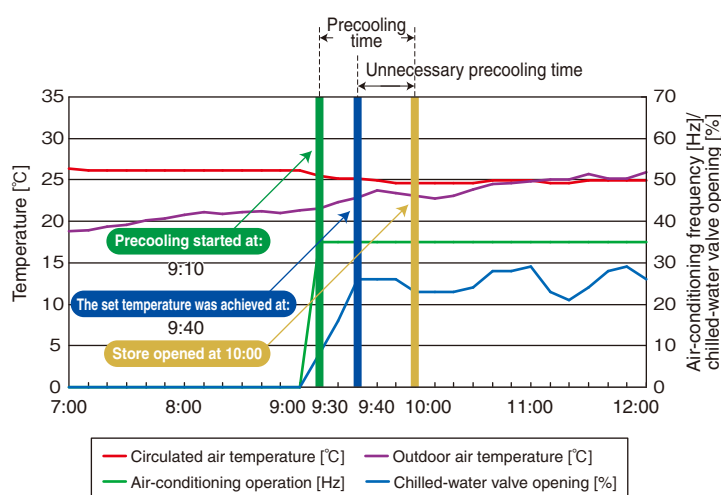

- It was found out that the precooling time could be shortened for about 15 minutes during winter and other seasons with moderate climate.

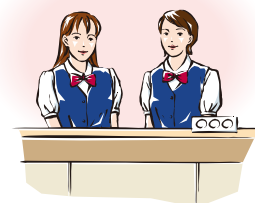

Successful Cases of Energy Conservation Measures of Commercial Facilities (2)

Successful energy conservation measure at department store - 2

(1) Heat source (for cooling) of individual water-cooling heat pump packages was operated and regulated to maintain its water temperature at or above 25°C throughout the year. However, by lowering the temperature to 15°C, which is the minimum temperature guaranteed by its manufacturer, during winter and the following season with moderate climate (from November to April), an energy conservation was achieved.

Impact by the changed temperature setting of heat source

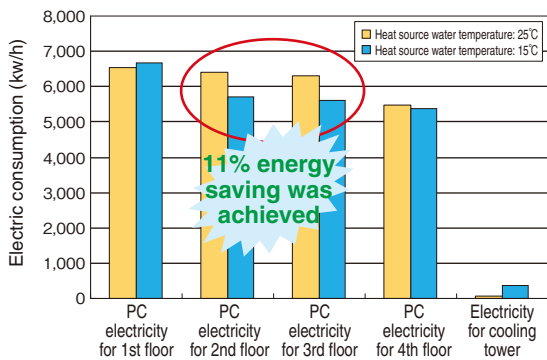

11% energy saving was achieved on the 2nd and 3rd floors. Only low impact was given on the 1st and 4th floors since heating and cooling were required on those floors.



System diagram of individual water-cooling heat pump package

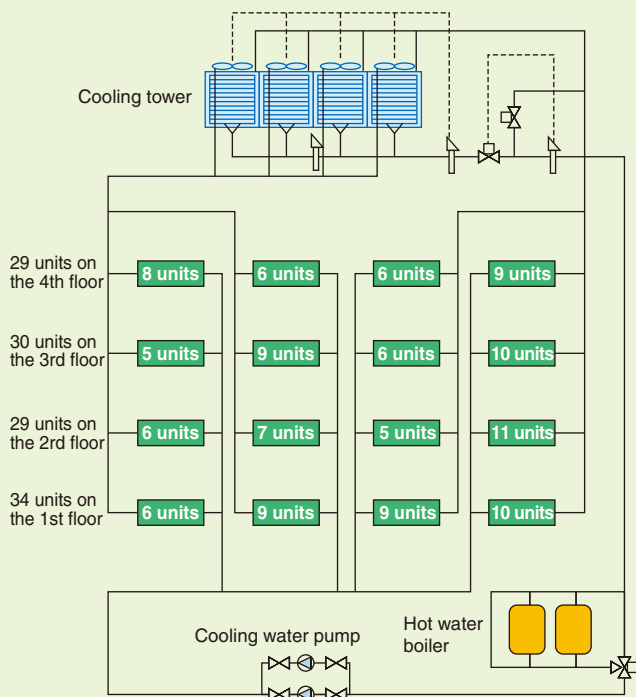

Cooling-water temperature (temperature settings from 28°C to 18°C)

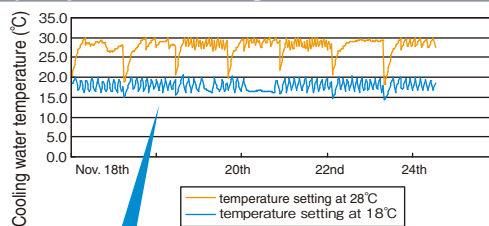

11% energy saving can be achieved by lowering the temperature setting of heat source water by 10°C

Cooling water temperatures and electric consumption by individual PAC

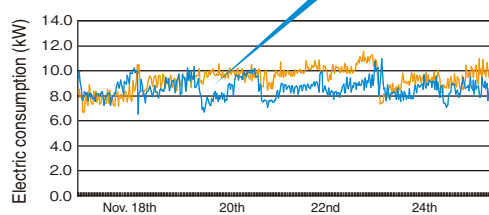

*Note: Thermal load of the air-conditioning was considered to be the same due to the fact that difference in outdoor air temperatures before and after implementing the measure was within 1°C.

6

Successful Cases of Energy Conservation Measures of Commercial Facilities (3)

Successful energy conservation measure at department store - 3

Energy conservation was achieved by raising temperature setting, by 2°C, for chilled water at an outlet of a centrifugal (turbo) chiller, which is heat source equipment for air-conditioning units, during winter and other seasons with moderate climate.

Conditions

- Energy consumption performance was compared before and after changing temperature setting for chilled water at an outlet of the centrifugal chiller from 6.5 to 8.5°C. The following graph illustrates changes in COP of the chillers when load factor varied between 20 and 100% at 6.5 and 8.5°C of temperature setting. Actual temperature range for the 6.5°C setting was between 6.4 and 7.6°C, and for the 8.5°C setting was between 8.4 and 9.4°C.

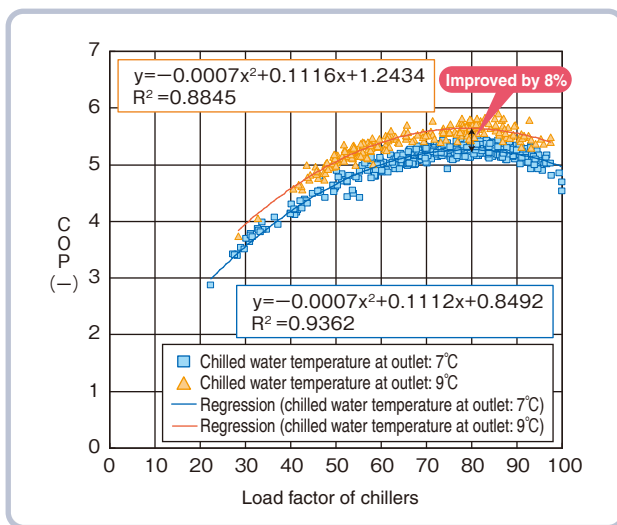

Results

- As shown in the upper-left graph, the change of the temperature setting of chilled water at an outlet from 6.5 to 8.5°C has improved COP of the centrifugal chiller at 80% load from 5.27 to 5.69, demonstrating a 8% increase.
- During winter and other seasons with moderate climate, this measure could achieve reduction of power consumption by heat source equipment for cooling.
- Only the primary pump is used to send the chilled water, without requiring additional heat-conveying power.

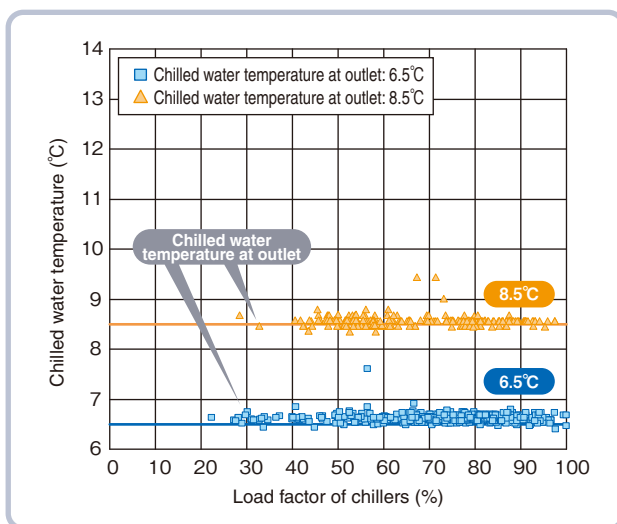

Conditions for data selection

- Only the data which satisfied the following conditions were selected and used for the comparison.
- Cooling water temperature: between 25.7 and 26.3°C
- Load factor of chiller: between 20 and 100%

7

Effective Tools and Techniques for Promoting Energy Conservation by Improved Operation

ECCJ provides tools and techniques for further energy conservation useful for improving operations of large-scale buildings for business use without charge.

The three tools and techniques are:

① ESUM: Energy Specific Unit Management Tool

ESUM is computer software which estimates energy consumptions of a building and compares the consumptions before and after implementing an energy conservation measure to demonstrate the energy reduction effect.

② TuBE: Tuning of Building Systems for Energy Conservation

TuBE is a document which defines how to select and carry out operational improvement actions among various energy conservation measures.

③ EAST: Energy Analysis Support Tool

EAST is computer software which compiles operation process data of air-conditioning units and heat source equipment and make a graphic presentation of the trends to help you analyze their operation conditions.

Combined use of the above three tools helps your making smoother energy conservation activities throughout the necessary steps for the activities; analysis on operation status and conditions, selection of improvement method, estimation of its effectiveness, and implementation of the measure.

How to obtain more detailed information on energy conservation of buildings for business use

ECCJ has a website to provide various kind of information on energy conservation of buildings.

The site includes:

- inputs from actual users of tools (e.g. ESUM and EAST) useful for enhancing your energy conservation activities for buildings;
- various forums for different types of facilities (e.g. office buildings, commercial facilities, hotels, and hospitals), which serve as an information exchange forum among members; and
- invitations to seminars and lecture classes which provides information on successful cases of improved energy conservation of buildings for business use and examples of effective use of various tools as well as materials for those seminars and lectures



URL <http://eccj06.eccj.or.jp/bldg/index.php>



The Energy Conservation Center, Japan

Internet URL <http://www.eccj.or.jp>

■ **Head Office** : 3-19-9, Hatchobori, Chuo-ku, Tokyo, 104-0032 Japan
Tel: 81-3-5543-3018 Fax: 81-3-5543-3022

This is translated from the original Japanese document.
For precise information and nuances, please refer to the original.